



ACTAtek™



Distributor Presentation

Best possible services;
Best possible solutions;
Best possible technologies.

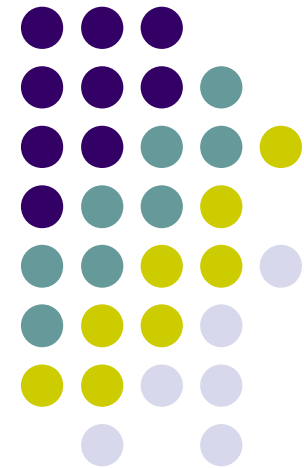



Company Overview

ACTAtek** backed by Venture Fund, Thomrose Holdings, with outstanding track record**

- | **Sold ValenceTech, an award winning Fabless Chip Product Company, to SRSL (NASDAQ: SRSL)**
- | **Early Investor in Central Semiconductor Manufacturing Corp, 2000. IPO in (HK:0597) 2004**
- | **Backed Advanced Card Systems Limited (ACS) – Leading Technologist in Smart Card systems. (HK: GEM 8210)**
- | **Major Shareholder of BCT Technology Berhad (MESDAQ:0130)– First Fabless Chip Company to be listed in Mesdaq Malaysia in July 2006.**
- | **Angel Investor of B.E.L. Systems – An ERP/MRP, CRM and Retail Management enterprise software company**

An Award Winning Product



- | **International Awards for ACTAtek**
 - | Mar 2004 - Cebit features new product: Actatek
 - | Mar 2005 - Linux Pilot Editor's Choice for Secure Access and Time Attendance System
 - | Jun 2005 - BiometriTech Product of the Year 2004, New York
 - | Jun 2005 - Linux Business Award Enterprise Product 2005
 - | Oct 2005 - Greater China Golden Penguin Linux Open System Award
 - | Oct 2005 - Finalist of Access Control & Security Systems USA: Winner of 2005 Product of the Year USA
 - | Nov 2005 - SC Awards 2006 Best of Biometric Device of USA
 - | May 2006 - Finalist of AeA High-Tech Innovation Awards – USA
 - | Apr 2007 - Finalist of AeA High-Tech Innovation Awards – USA
 - | June 2007 – Listed as one of the Hot 50 Security Companies in the World by InfoSecurity



ACTAtek Product Position



For Automated Access Control and Time Attendance providers

Who are dissatisfied with traditional access control and time clocks

Our product is a Linux web-based biometric and RFID card open system

- That supports all legacy card-based systems whilst allowing immediate integration with your IT and security systems and infrastructure
- Unlike products from Kronos, HID, Bioscrypt, Ingersoll Rand and Sagem
- We have assembled all the hardware and software interfaces needed for third-parties application integration with their existing IT and security systems



Distributor Scheme



We have a few selected non-exclusive distributors for each territory focusing upon different market verticals

Distributors will have their own installer/reseller/VAR network

Listed Distributor Price by Quantity

- Customer protection scheme per terms and conditions in distributor agreement, typically 3-6 months with monthly report update to ACTAtek
- Our pricing strategy allows distributor to make significant profit per unit
- Apart from the 12 months warranty, ACTAtek is the only biometric product offering extended 24 months and beyond warranty scheme allowing Distributor to make future profit



Training for Distributors



- | We provide free training of the ACTAtek system provided your personnel attend our 2 days training in one of our world-wide offices.
- | Distributor to bear all cost of the personnel sent for such training
- | For the first major multiple unit installation, we will send a support engineer to assist and train your staff to install the units

- ACTAtek will bear the air and accommodation of its engineer for this installation
- Many distributors' engineers will have no experience in IT technology, web-based systems and biometrics products
- It would be very expensive just to send your engineer to such commercially available course, ACTAtek doing it for FREE!



Revenue for Distributors



- | ACTAtek is design for durability and reliability in mind, hence the casing is IP65 certified
- | Pricing at less then US\$1 per user allows plenty of margin for distributor and its network
- | Our warranty scheme allows distributor to generate future recurring revenue whilst keeping them in contact with customers for further sales

- ACTAtek supports all legacy card-based system be it bar-code, HID, Proximity
- Distributor customers don't have to migrate over to ACTAtek immediately as the old and new system can co-exist until the old one is replaced
- ACTAtek is network ready and web-based, allowing customers to scale their installation generating further revenue for Distributor!



Tech Support for Distributors



- | ACTAtek Tech Support will call your appointed support engineer on a monthly basis to give them update and further information of how to use the product and its system software
 - | All bugs and feature request can be reported to support@actatek.com
 - | We have 24 hours coverage of the email sent to us
-
- Distributor can download all kind information, technical specification, marketing and promotional material from the Customer Support Centre on our website, www.actatek.com
 - Customised feature at a charge can be discussed
 - Unique tracking for all report file with ACTAtek





Product Overview

I ACTAtek

- I **100% stand-alone** with all software & hardware built-in
- I **Network ready** for scalable multiple unit deployments
- I Simple to install, effective, reduces overhead/running costs & fully compatible with your IT system
- I **Real-time tracking employee attendance** records, irrespective of geographic locations for disaster management
- I **SSL-Encrypted** highly secure web based network
- I **IP65 Impact resistant, water & dust proof** casing
- I **3-way authentication** with biometric fingerprint, smart card (HID iClass, HID Proximity, Sony Felica, Legic, Mifare, EM, barcode and contact smart cards) & PIN with built-in CMOS camera!
- I Open Linux OS supporting SQL database. SDK for 3rd-parties application integration via SOAP, SNMP and LDAP support



Product Overview

- | **Multi-Lingual Support** – currently supports English, Spanish, Chinese (Simple & Traditional), Croatian, French, German, Korean, Portuguese, Spanish and Thai with more in the future!
- | Maximum Fingerprint user enrollment of **20,000 users**.
- | Maximum Smartcard user enrollment of **30,000 users**.
- | Maximum Photos stored **1,000**
- | Transaction records stored of **75,000 records**.
- | **Real time** system update and configuration!
- | Supports **Weigand 26-bit & 40-bit** output!
- | Optional **IP camera** support!
- | Optional **SMS messaging & Wi-Fi Support!**



Product Overview – Roadmap for 2008



- | Maximum Fingerprint user enrollment of **40,000 users***.
- | Maximum Smart Card user enrollment of **60,000 users***.
- | Maximum Photo storage of **2,000 photos***.
- | Maximum transaction records stored of **150,000 records***.
- | New Casing
- | Different models for Access Control and Time Clock
- | External **HID, Legic, Sony Felica readers**
- | Super Primary for over 40,000 users
- | More powerful SDK and API
- | And more features to come!

*depending upon chosen model





Customer Installations

- | With @20,000 installations including
 - | **IBM**
 - | **Indonesian Parliament**
 - | **Coca-Cola**
 - | **BMW, Toyota, Fiat**
 - | **Bangkok High Way Toll-Road Management**
 - | **University of Cambridge**
 - | **British Petroleum**
 - | **KFC**
 - | **Macau, Hong Kong, Qatar and other Governments**
 - | **Dubai International Airport**
 - | **Banks: North Shore Bank USA, National Bank of Qatar**
 - | **Motorola**
 - | **Hyatt Hotel**





A Standard Connection:

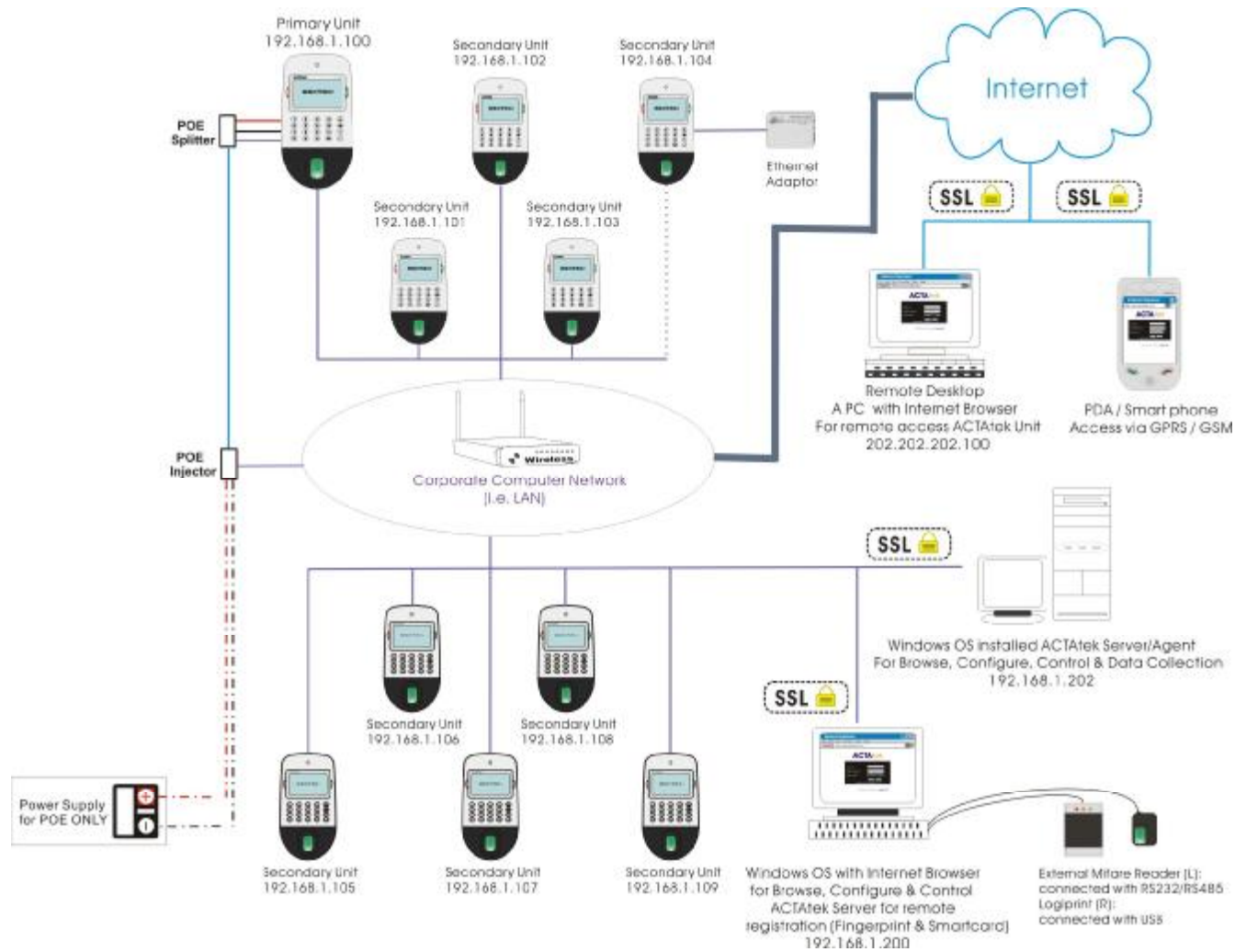



Contact ACTAtek

- | ACTAtek can be contacted at:
 - | North Asia Customers:
 - | + (852) 2319-1333, E-mail: sales-row@actatek.com
 - | ASEAN Customers:
 - | + (65) 6515-4520, E-mail: sales-asean@actatek.com
 - | Europe, Middle East / Africa customers:
 - | +44 (121) 411-2288 , E-mail: sales-eu@actatek.com
 - | USA customers:
 - | +1 (714) 505-0433, E-mail: sales-us@actatek.com
 - | Canada customers:
 - | +1 (604) 278-8888, E-mail: sales-ca@actatek.com
 - | Website: <http://www.actatek.com>

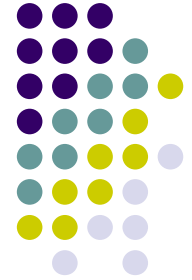

Q & A Session

